

Assembled example isometric view

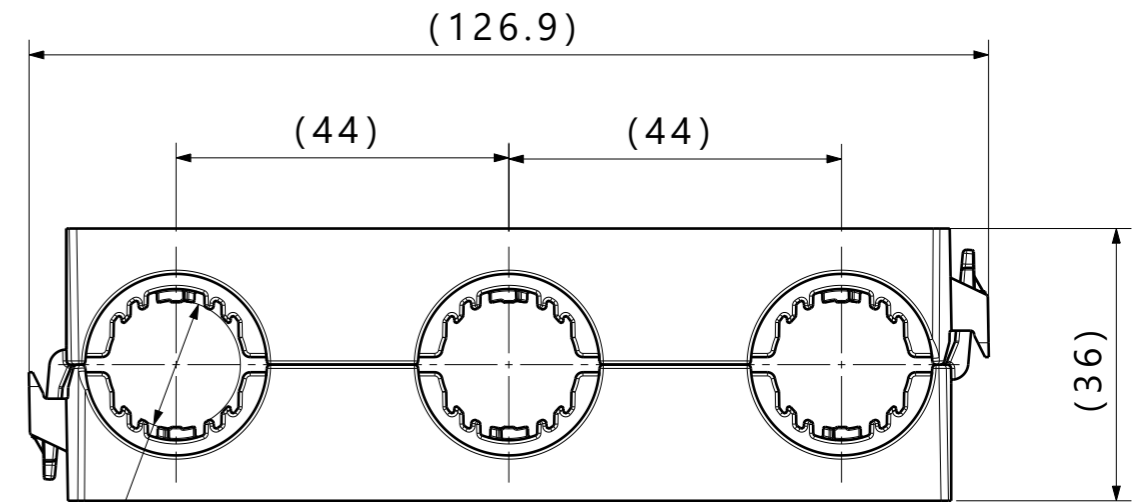

Assembled example front view

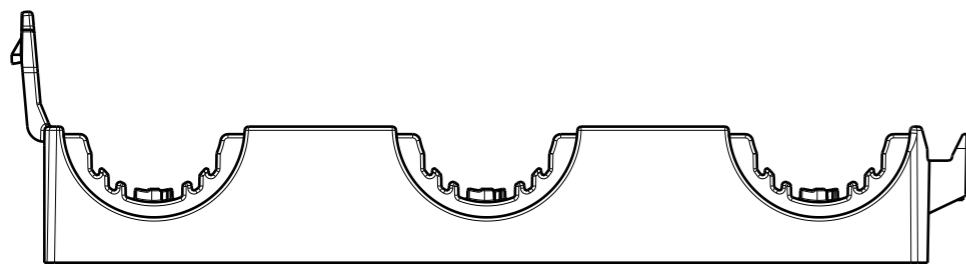

Delivery condition

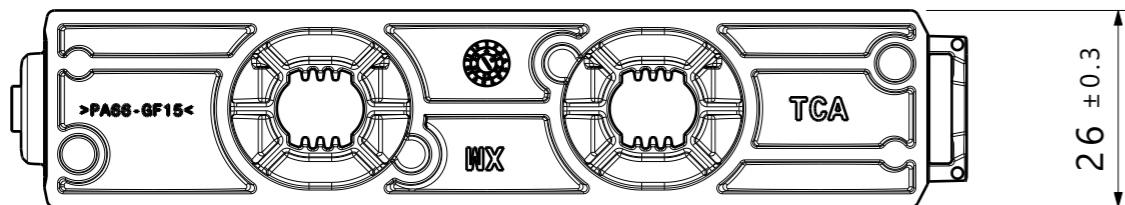
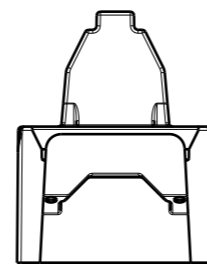

Notes:

1. Material: See chart
2. Material color: See chart
3. Maximum percent regrind permissible: 0%
4. Max allowable flash to be: 0.50mm
5. Max allowable mismatch to be: 0.1mm
6. Threaded stud length to be at least: 40mm
7. Applicable stud size:

A. M8 x 1.25 Threaded

Global Part Description	Housing		
	Drawing	Material	Color
HDC17X3BASE-PA66GF15/TPE-BK	23-0183-005-CSU	PA66GF15/TPE	Black

Revision Level			Revision Record	
Drawing	State	Part	ECN 310621	
00.2	Design Release			
Changed	Date (YYYY/MM/DD)			
Rohde	2023/12/13			
Approved	Date (YYYY/MM/DD)			
Van Hulst	2023/12/13			

The copyright of this drawing is reserved by HellermannTyton.

All drawing revisions are stored in CAD PDM database

Units: mm

Drawn: Rohde, Date: 2023/12/13

Approved: Van Hulst, Date: 2023/12/13

HellermannTyton
www.HellermannTyton.com

Title: Triple clamp with 17mm hose cover

Scale: 1:1

Global Project Number: 23-0183

Format: A3

Sheet: 1 / 1

Drawing-No: **23-0183-105-CSU**